

IMPORTANT: Please read all of the instructions before installation.

General:

- Methven recommends this product is installed by a licensed plumber in compliance with all relevant regional regulations.
- All pipe work must be thoroughly flushed prior to the installation of the mixer.
- In-line filters must be fitted on both hot and cold supplies to prevent foreign particles damaging the ceramic cartridge.
- After installation all connections must be checked for leaks.
- All outlets used primarily for personal hygiene shall deliver water at a safe temperature as per regional regulations.
- This mixer is not recommended for use in uncontrolled heating systems such as wet-backs or solar heating units unless a suitable tempering valve is fitted.
- It is the responsibility of the installer to ensure a waterproof seal is achieved between the product and mounting surface. If in doubt about the quality of the seal, remove the product and reinstall using silicone to ensure a seal is achieved.

MINIMALIST MK2 SHOWER MIXER WITH FASTFLOW Installation Guide

Technical Specifications:

Operating Pressure:

Unequal Pressure:
Hot: Min 17kPa
Cold: Min 30kPa

Equal Pressure:
Min 35kPa
If supply exceeds 500kPa a pressure limiting valve must be installed.

Operating Temperature:

Hot: Min 55°C (at mixer), Max 80°C
Cold: Min 5°C

Inlet Connections:

All 1/2" BSP

** Regional specific regulations apply.
Please refer to your warranty statement
at www.methven.com*

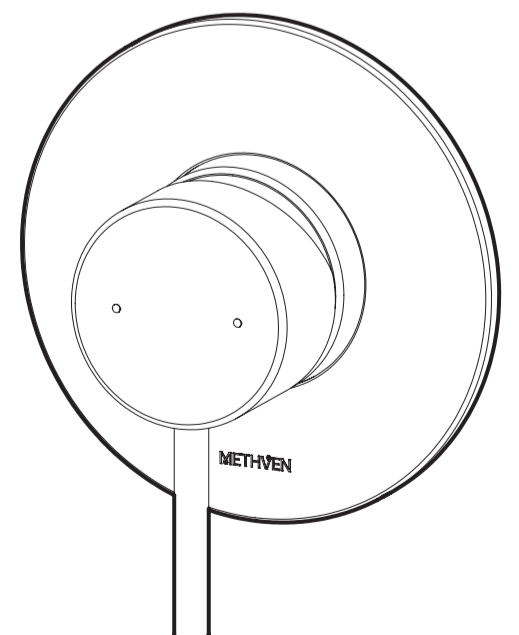

Care and Cleaning:

Never use abrasives or abrasive cleaning agents to clean this product. Clean regularly with contamination free warm soapy water and a damp soft cloth.

Methven warrants this product against manufacturing defects and that it is suitable for use under the general operating conditions specified in this instruction sheet. However, regional regulations apply and may affect your warranty. Please refer to www.methven.com or call customer service for full details.

JET SELECTION:

Equal Pressure Systems

Fit mixer as supplied.

Unequal Pressure Systems

If the system is supplied by a pressure pump, ensure that the pump can maintain 300kPa at the cold Inlet. If not, install a low pressure cold feed and install the mixer as if for a low pressure equal system.

Use the following table to determine the nozzle to be used.

Hot Pressure	Primary Nozzle
17-25 kPa	Black
25-50 kPa	Green
50-90 kPa	Yellow
90-130 kPa	Red

Fitment of the primary nozzle into the mixer body

- Remove the dome cover and unscrew the lock nut.
- Take hold of the cartridge and with a gentle circular motion pull the cartridge straight out of the mixer body. Note: Do not turn the cartridge.
- Fit the recommended nozzle into the cartridge as shown as per the table.
- Refit the cartridge ensuring that the 2 outer seals are in place. Refit the lock nut applying a torque of 12 Nm and refit the dome cover.

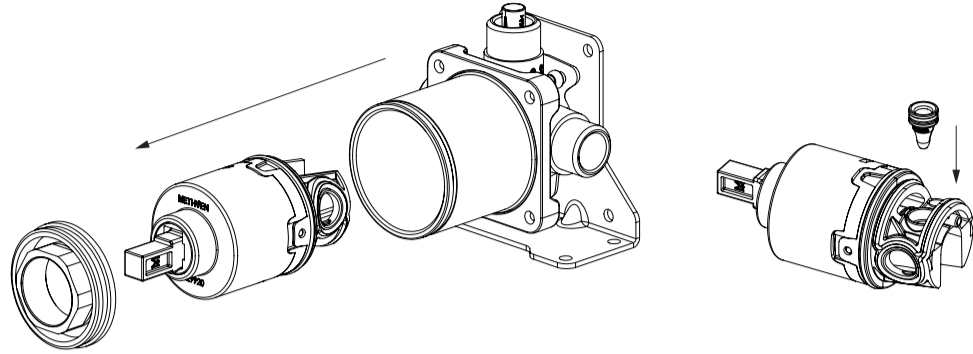

IMPORTANT: Before you begin, turn off the water supply.

Step 1

- Refer to section above for correct nozzle selection.
- Install a horizontal support at the required height for correct positioning of the mixer. Ensure front of horizontal support is in line with front of the framing.

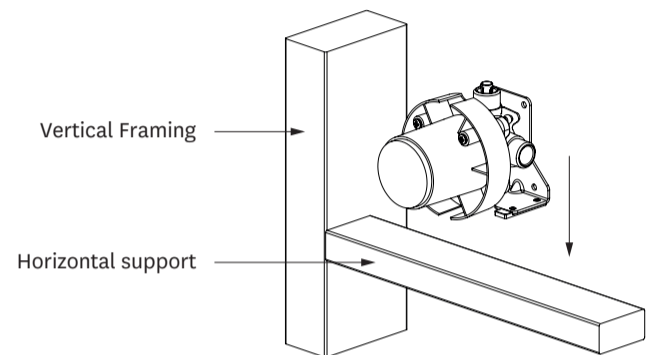

Step 2

For thin wall linings (eg acrylic showers):

- Position mixer body on horizontal support with the front edge of the black spacer flush with front of the horizontal support.
- If necessary, loosen the plastic cover and leave in place during the installation.

For thicker wall linings (eg tiles):

- Remove black spacers from under the mounting bracket.
- Position mixer body on horizontal support with the front edge of the mounting bracket flush with front of the horizontal support.
- Secure mixer body to the horizontal support with four suitable screws, ensuring it is oriented square.
- Alternatively, the mixer can be mounted to support timber behind the mixer maintaining the same placement as above.

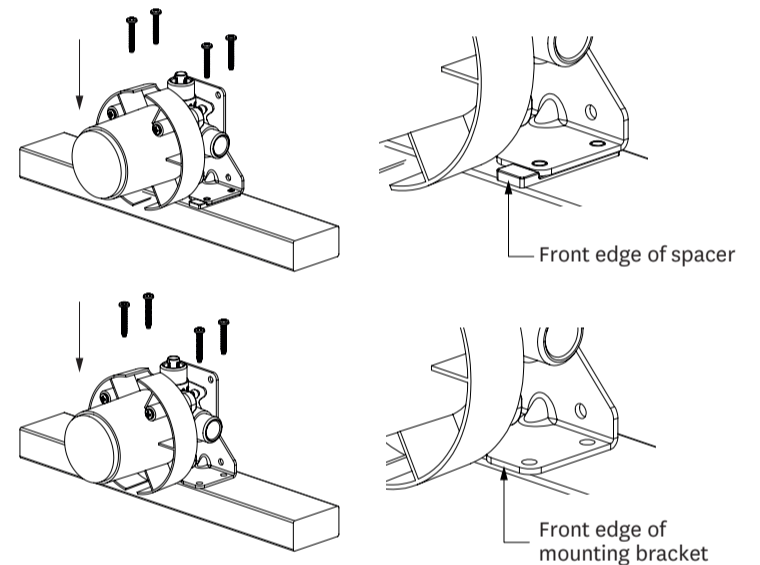

Step 3

- Flush all pipe-work thoroughly prior to the next step.
- Connect hot and cold supplies and outlet to mixer body ensuring a good seal at each joint.
- Leak test installation prior to closing wall cavity.
- The seal integrity of pipe joins is the responsibility of the installing plumber.

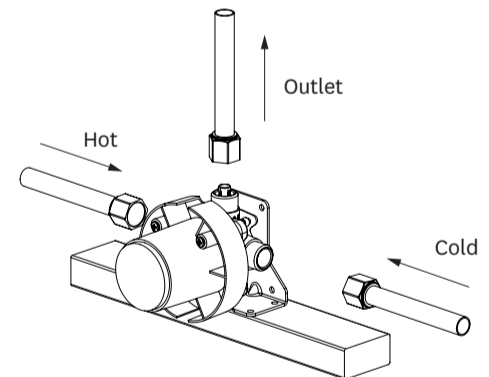

Step 4

- Wall lining hole should be cut or finished as per the dimension shown in the diagram on the right.
- Allowable distance from front of horizontal support to finished wall surface:
 - With spacer = 2 - 22mm
 - Without spacer = 8 - 30mm

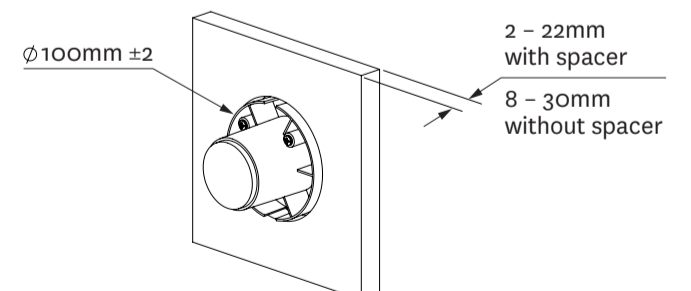

Step 5

- Remove plastic cover.
- Fit dome cover by screwing it onto the locknut and hand tighten.
- Fit faceplate rubber seal to ID of faceplate.
- Apply silicon to the rear of faceplate keeping the drainage notch clear.
- Fit faceplate onto protruding barrel and press up against the finished wall surface ensuring that the drainage notch is at the bottom.
- Push the handle body onto cartridge lever and secure by tightening the grub screw with the hex key provided.
- Screw the handle pin lever onto the protruding grub screw and hand tighten.

